



## Specifications



# GE Infrastructure Water & Process Technologies Merlin™ Reverse Osmosis Systems

### System Performance Specifications

**Average Permeate Flow Rate** → 0.75 Gallons/Minute (2.84 Liters/Minute)  
or  
1080 Gallons/Day (4,090 Liters/Day)

**Average TDS Rejection** → 95% NaCl

Based on 3.44 bar (50 psi), 25°C (77°F), 750 mg/L NaCl, 33% recovery

### Minimum and Maximum Performance Specifications\*

Specification	Minimum	Maximum
Permeate Flow Rate	0.50 Gallons/Minute (1.90 Liters/Minute)	1.0 Gallons/Minute (3.78 Liters/Minute)
TDS Rejection (NaCl)	90%	99%
Concentrate Flow	1.0 Gallons/Minute (3.80 Liters/Minute)	2.0 Gallons/Minute (7.56 Liters/Minute)

Based on 3.44 bar (50 psi), 25°C (77°F), 750 mg/L NaCl, 33% recovery

### System Dimensions

**Height** → 17.05 inch (43.3 cm)  
**Length** → 20.34 inch (51.7 cm)  
**Depth** → 9.68 inch (24.6 cm)

\*Pending final product testing





## Minimum and Maximum Operating Conditions

Condition	Minimum	Maximum
Inlet Pressure	40 psi (2.76 bar)	80 psi (5.52 bar)
Inlet Temperature	40° F (4.44° C)	100° F (37.78° C)
Inlet TDS	50 mg/L	2,000 mg/L
Inlet Hardness	0 mg/L - (0 grain)	171 mg/L - (10 grain)
Inlet Chlorine	0 mg/L	1.0 mg/L
Inlet Iron	0 mg/L	0.3 mg/L
Inlet Manganese	0 mg/L	0.1 mg/L

\*System is designed for use on potable water sources only.

## Tubing/Fitting Dimensions

- Inlet Tubing** → 4 feet of 1/2" natural tubing  
(1.22 meters of 12.7 mm natural tubing)
- Concentrate Tubing** → 4 feet of 3/8" black tubing  
(1.22 meters of 9.53 mm black tubing)
- Permeate Tubing** → 4 feet of 3/8" blue tubing  
(1.22 meters of 9.53 mm blue tubing)
- Drain Tubing** → 3 feet of 1/2" red tubing  
(0.91 meters of 12.7 mm red tubing)
- Drain Connection** → 1/2"  
(12.7 mm)
- Carbon Post Filter** → 3/8" quick disconnect fittings  
(9.53 mm quick disconnect fittings)
- Inlet Connection (Option 1)** → 3/8" x 3/8" x 1/2" tee  
(9.53 mm x 9.53 mm x 12.7 mm tee)
- Inlet Connection (Option 2)** → 1/2" x 1/2" x 1/2" tee  
(12.7 mm x 12.7 mm x 12.7 mm tee)

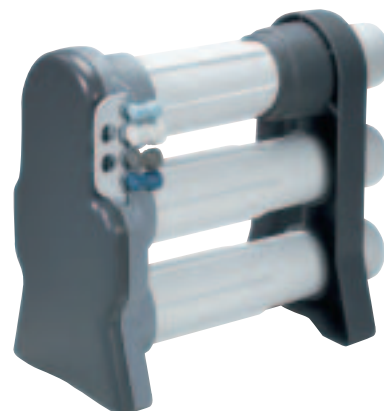



## Filter/Membrane Performance Specifications

FILTER TYPE	DIMENSIONS		FLOW RATE	PRESSURE DROP	AVERAGE LIFE
	Length	Diameter			
Carbon Prefilter	17.0"	2.9"	3.75 GPM (14.2 LPM)	3 psi	6 months
RO Element	18.75"	3.16"	0.375 GPM (1.42 LPM)	Pending Final Testing	3 years
Carbon Postfilter	10.5"	2.6"	.750 GPM (2.8 LPM)	Pending Final Testing	6 months

Based on:

50 psi (3.4 bar), 77° F (25° C), 750 mg/L NaCl, 33% Recovery, 1.0 mg/L inlet chlorine

## Options

- Booster Pump → For low pressure applications
- Membrane Rinse System → Permeate flushing accumulator
- Ice Maker Installation Kit → Connections to 1/4" ice maker line

## Outline Dimensions – Inches (cm)

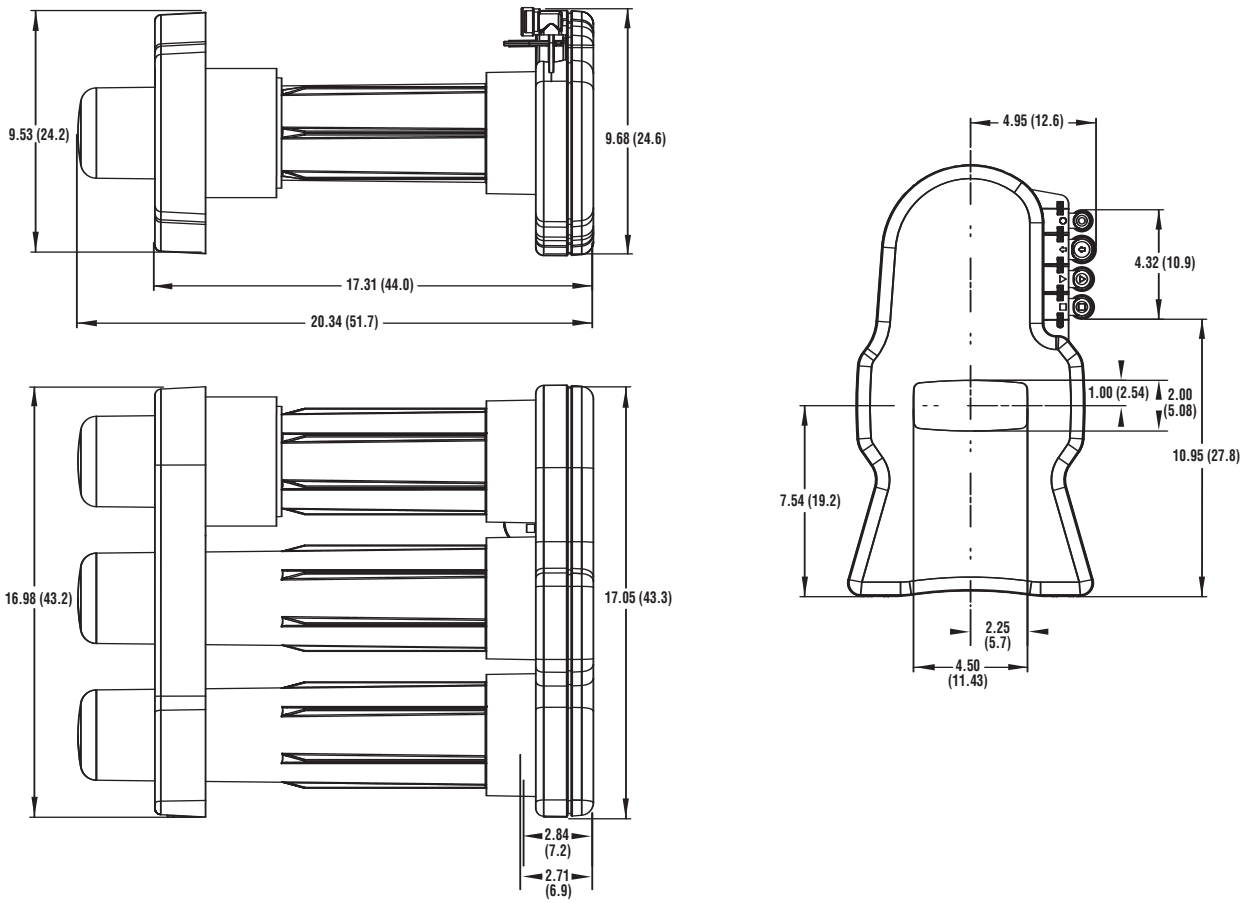



### Estimated System Flow Rate (GPM) Temperature vs. Pressure @750ppm NaCl/RO

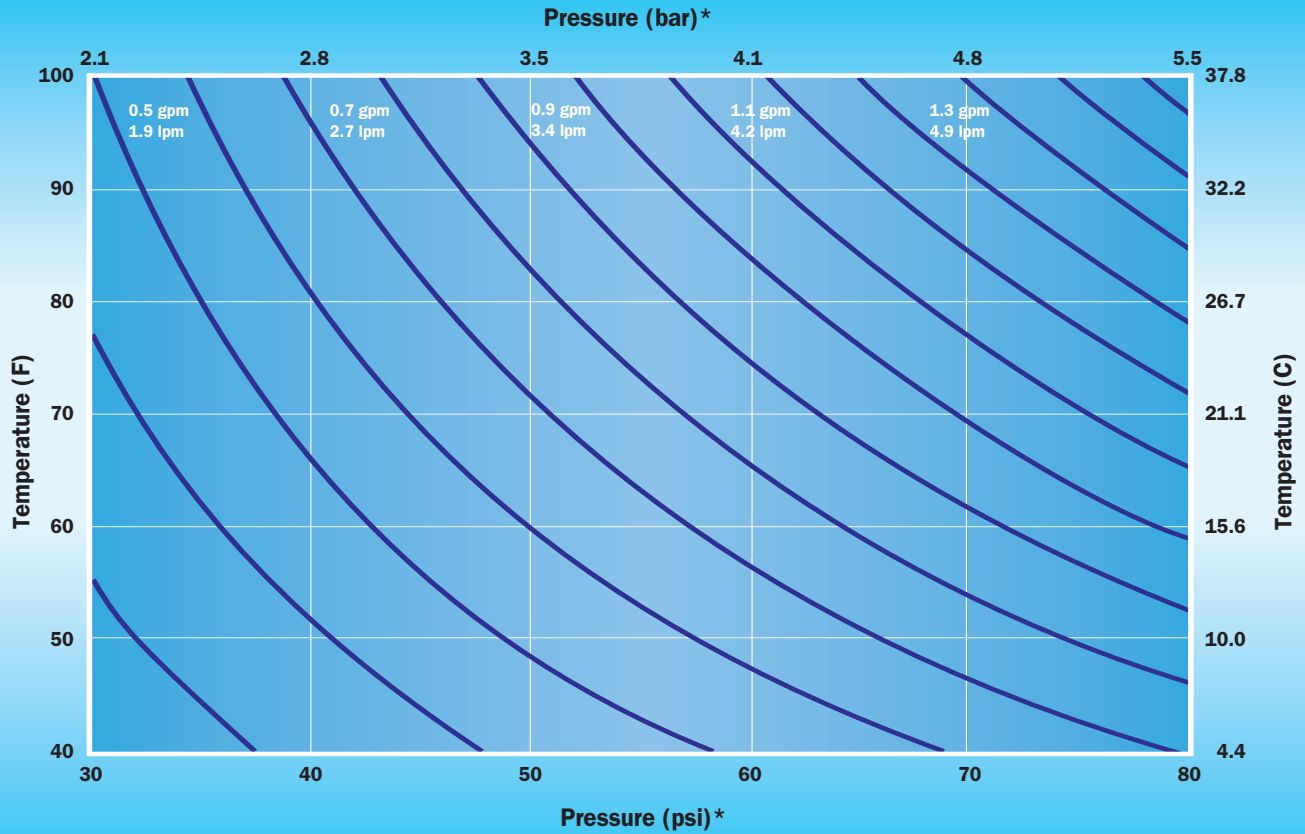

\*Pressure measured at membrane element inlet.

**Flow Adjustment Based on TDS**  
Estimated Flow Change from  
750ppm NaCl/RO = -0.0002 (TDS) + 0.15

#### For More Information:

Call **GE Infrastructure Water and Process Technologies; Household Water Group** at **(262) 238-4400** or **(800) 279-9404**, or visit **www.gewater.com**



#### North American Sales

5730 N. Glen Park Road  
Milwaukee, WI  
53209-4403  
USA  
(262) 238-4400 Phone  
(262) 238-4402 Fax

#### Euro/Africa Operations

230 rue Robert Schuman  
ZA des Uselles  
F-77350 Le Mée sur Seine  
FRANCE  
+33 1 64 10 2000 Phone  
+33 1 64 10 3747 Fax

#### Asia/Pacific Operations

1044/8 Soi 44/2  
Sukhumvit Road Parkanog  
Bangkok 10110  
THAILAND  
+66 2 38 14213 Phone  
+66 2 39 18183 Fax

